

FR-D700

INVERTER

Instruction Manual



Safety stop function



INVERTER FR-D700

Safety stop function instruction manual

CONTENTS

1. General description	1
2. Installation and wiring	2
3. Example of safety system configuration	5
4. Test and checking failure	8

Compliance with the EU Machinery Directive – Functional Safety

DANGER

Any misuse of safety function could lead to personal injury or death, property damage, or economic loss. To ensure that the system complies fully with requirement of safety, make a system-level risk assessment. Mitsubishi Electric Co. cannot assume responsibility for any system to comply with safety directive.

ATTENTION

The information of this manual is merely a guide for proper installation. Mitsubishi Electric Co. cannot assume responsibility for the compliance or the noncompliance to any code, national, local or otherwise for the proper installation of this equipment. A hazard of personal injury and/or equipment damage exists if codes are ignored during installation.

DANGER

To avoid an electric shock hazard, verify that the voltage on the bus capacitors has discharged before performing any work on the drive. Measure the DC bus voltage at the P(+) and N(-) terminals or test points (refer to your drive's *User Manual* for locations and discharging time). The voltage must be zero.

DANGER

The safety stop function do not isolate electrically between drive and motor. To avoid an electric shock hazard, disconnect/isolate power to the drive and verify to ensure that the voltage is zero before performing any work on the motor (refer to your drive's *User Manual* for discharging time).

ATTENTION

If you are using a FR-D740-EC or FR-D740-CHT with serial number shown below, safety function does not work according to safety standard. In such case please contact your sales person.

<Europe model : suffixed with '-EC'>

D740-012 to 080-EC : Axxxxx, Bxxxxx, Cxxxxx, Dxxxxx, Exxxx and Fxxxxx

D740-120 to 160-EC : Axxxxx, Bxxxxx, Cxxxxx and Dxxxxx

<China model : suffixed with '-CHT'>

D740-0.4K to 3.7K-CHT : Axxxxx, Bxxxxx, Cxxxxx, Dxxxxx, Exxxx and Fxxxxx

D740-5.5K to 7.5K-CHT : Axxxxx, Bxxxxx, Cxxxxx and Dxxxxx

1. General description

Features

Mitsubishi FR-D700 safety stop function prevents a drive from supplying rotational energy to motors. Dual safety channels 'S1' and 'S2' cut off the gate-drive power for IGBT to turn off.

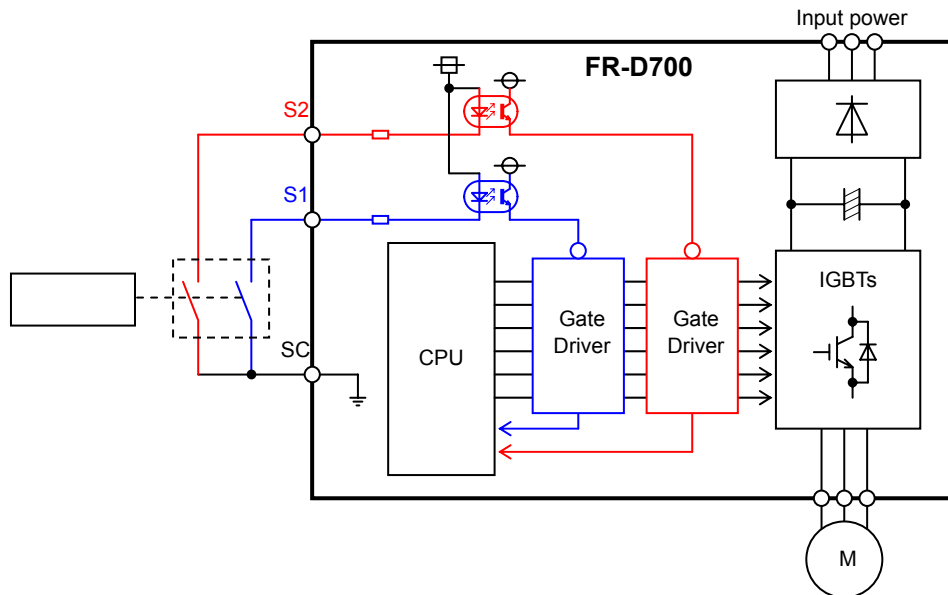

Fig.1 FR-D700 safety stop function diagram

DANGER

The safety stop function doesn't isolate electrically between drive and motor. To avoid an electric shock hazard, disconnect power to the drive and verify that the voltage is zero before performing any work on the motor (refer to your drive's *User Manual* for discharging time).

Directives

Mitsubishi FR-D700 safety stop function meets the following directives and categories.

EN954-1 Category 3

IEC60204-1 Stop category 0

DANGER

The misuse of safety function leads to personal injury or death, property damage, or economic loss. To ensure that the system complies fully with requirement of safety, make a system-level risk assessment. Mitsubishi Electric Co. cannot assume responsibility for any system to comply with safety directive.

2. Installation and wiring

ATTENTION

The following information is merely a guide for proper installation. Mitsubishi Electric Co. cannot assume responsibility for the compliance or the noncompliance to any code, national, local or otherwise for the proper installation of this equipment. A hazard of personal injury and/or equipment damage exists if codes are ignored during installation.

ATTENTION

Ensure the safety relay unit and the D700 unit is mounted closely in enclosure meeting IP54 and all interconnection wiring is short and protected against open and short circuit faults. Refer EN/ISO13849-2.

Installation

Mitsubishi FR-D700 safety stop function should be used under following condition and environment.

Table.1 The condition and environment for using safety stop function

Item		Condition
Temperature range	Operation	-10Cto+50C (non-freezing)
	Storage	-20Cto+65C
Ambient humidity		90%RH maximum (non-condensing)
Vibration		5.9m/s ² or less
Altitude		maximum 1000m above sea level
Atmosphere		Indoors (without corrosive gas, flammable gas, dust and dirt etc.)
Over voltage category		II or less
Pollution degree		II or less
Mounting		wall mounting / vertical orientation

ATTENTION

In order to meet safety stop, an approved safety relay unit to EN954-1 safety category 3 or better shall be used in conjunction with D700 as shown in example1,2. In addition, all other components with in the safety stop loop shall be 'safety approved' types.

DANGER

To avoid an electric shock hazard, insert the magnetic contactor (MC) between power source and drive. Open the contact of MC and keep away from drive for discharging time (refer to your drive's *User Manual* for information) before performing any work on the drive. And verify that the voltage on the bus capacitors has discharged before Measure the DC bus voltage at the P(+) and N(-) terminals or test points (refer to your drive's *User Manual* for locations). The voltage must be zero.

ATTENTION

To avoid systematic faults, a test even for faulty demands of the safety function has to be performed in order to check the correct function of the monitor signal. This test shall be carried out at system installation, any software changes, parameterization changes, and/or at least once per year. Refer to '4. Test and checking failure'.

Wiring

The safety related terminals are described in Table.2 and Table.3

Table.2 The safety related terminals

Terminal Symbol	Description	Rating
S1	For input of safety stop channel1. S1-SC is Open: In safety stop mode. Short: Non safety stop mode.	Input resistance:4.7kOhm Current : 4 to 6 mA (In case of shorted to SC) Voltage : 21 to 26 V (In case of open from SC)
S2	For input of safety stop channel2. S2-SC is Open: In safety stop mode. Short: Non safety stop mode.	
SO	As output for safety stop condition. SO terminal type is 'Open collector output'. SO-SC is OFF(Open) :Drive enabled ON(Close) :Drive shutoff, no fault Important: SO terminal should be used for monitoring safety stop condition only. SO terminal cannot be used for safety function.	Load: 24VDC/0.1A max. Voltage drop: 3.4V max. (In case of 'ON' state)
SC	Common terminal for S1,S2,S0signals. *SC is connected terminal SD internally.	
RUN	As output for failure detection and alarm. RUN terminal type is 'Open collector output'. RUN-SE is OFF(Open): Detect failure or Alarm. ON(Close): No failure detected. Attention: To use RUN terminal for monitor output of failure detection, The parameter No.190 should be set 199 (Alarm output). Note: This terminal can be used for alarm or to prevent restart only, no other safety function.	Load: 24VDC/0.1A max. Voltage drop: 3.4V max. (In case of 'ON' state)
SE	Common terminal for safety RUN signal.	
A,C	As output for failure detection. A,C terminal type is 'Relay output'. A-C is OFF(Open): Detect failure or Alarm. ON(Close): No failure detected. Attention: To use A,C terminal for monitor output of failure detection, The parameter No.192 should be set 199 (Alarm output). Note: This terminal can be used for alarm or to prevent restart only, no other safety function.	Load: 30VDC/0.3A max.
SD	Signal ground	

Table.3 Truth table of Safety related signals

Input power	S1-SC	S2-SC	Failure	SO-SC	RUN-SE or A-C	Drive state
OFF	-	-	-	OFF(Open)	OFF(Open)	Drive shutoff (Safe state)
ON	Short	Short	No failure	OFF(Open)	ON(Close)	Drive enable
			Detected	OFF(Open)	OFF(Open)	Drive shutoff (Safe state)
	Open	Open	No failure	ON(Close)	ON(Close)	Drive shutoff (Safe state)
			Detected	OFF(Open)	OFF(Open)	Drive shutoff (Safe state)
	Open	Short	Detected	OFF(Open)	OFF(Open)	Drive shutoff (Safe state)

Wire and ferrule specification

Table.4 wire and ferrule specification

Wire size (mm ²)	Ferrule with insulation collar *	Crimping tool *
0.3 / 0.5	AI 0,5-10WH	CRIMPFOX ZA3
0.75	AI 0,75-10GY	
1	AI 1-10RD	
1.25 / 1.5	AI1,5-10BK	
0.75 (combined 2 wire)	AI TWIN 2 X 0,75-10GY	

*Ferrules and tools are distributed by Phoenix Contact.

Jumper cable

The jumper cable between S1,S2 and SC terminal has been installed in the factory as shown in Fig.2.

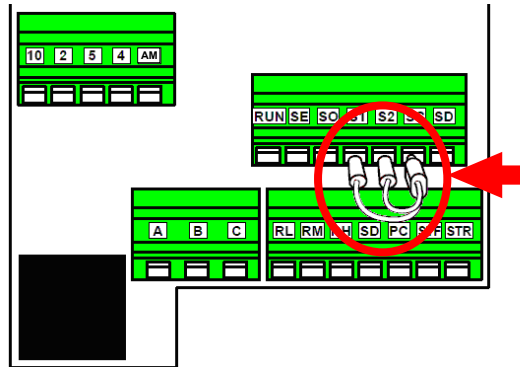

Fig.2. Short wire

Before connecting safety input wire to S1,S2 and SC terminal, remove this jumper cable.

3. Example of safety system configuration

Example 1

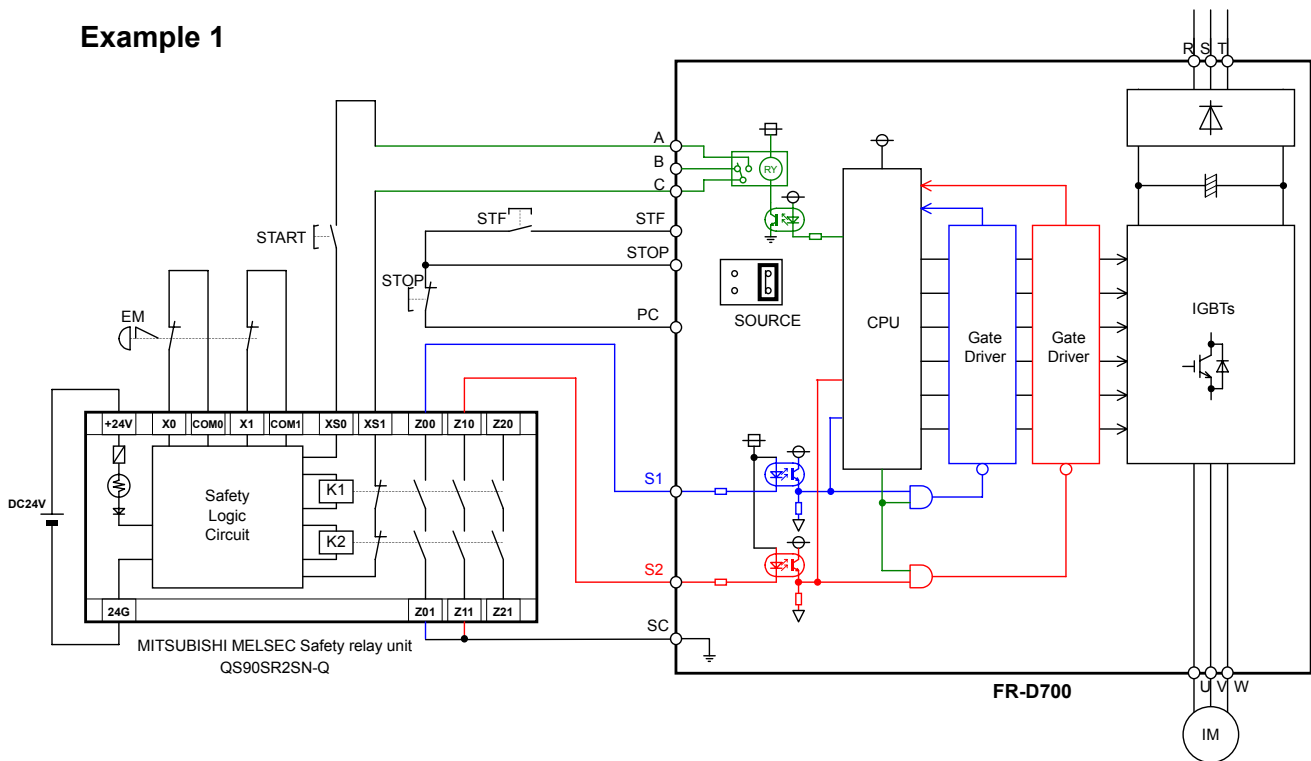

Fig.3 Safety system example 1 – STOP asynchronous with EM and fault detection through A-C output.

For safety stop, configure the wiring as shown in Fig.3 above.

Note: the above wiring is configured to prevent restart in case of a fault.

The parameter No.192 must be set to '199'. This setting makes the A-C output to open in case of failure.

After the power-up, to reset the safety stop mode, press the START switch, and also press the STF switch, then start the motor rotation.

In the above configuration, after reset of EM switch, drive will be in safe-state until START switch is pressed.

ATTENTION

To prevent restart in case of recovering from input power loss of drive, 3-wired connection for STF/STOP control is recommended.

In case of 2-wire connection and using latching type switch to short between STF and SD/PC for starting, ensure the compliance with safety requirement for the restarting when the drive recover from input power loss.

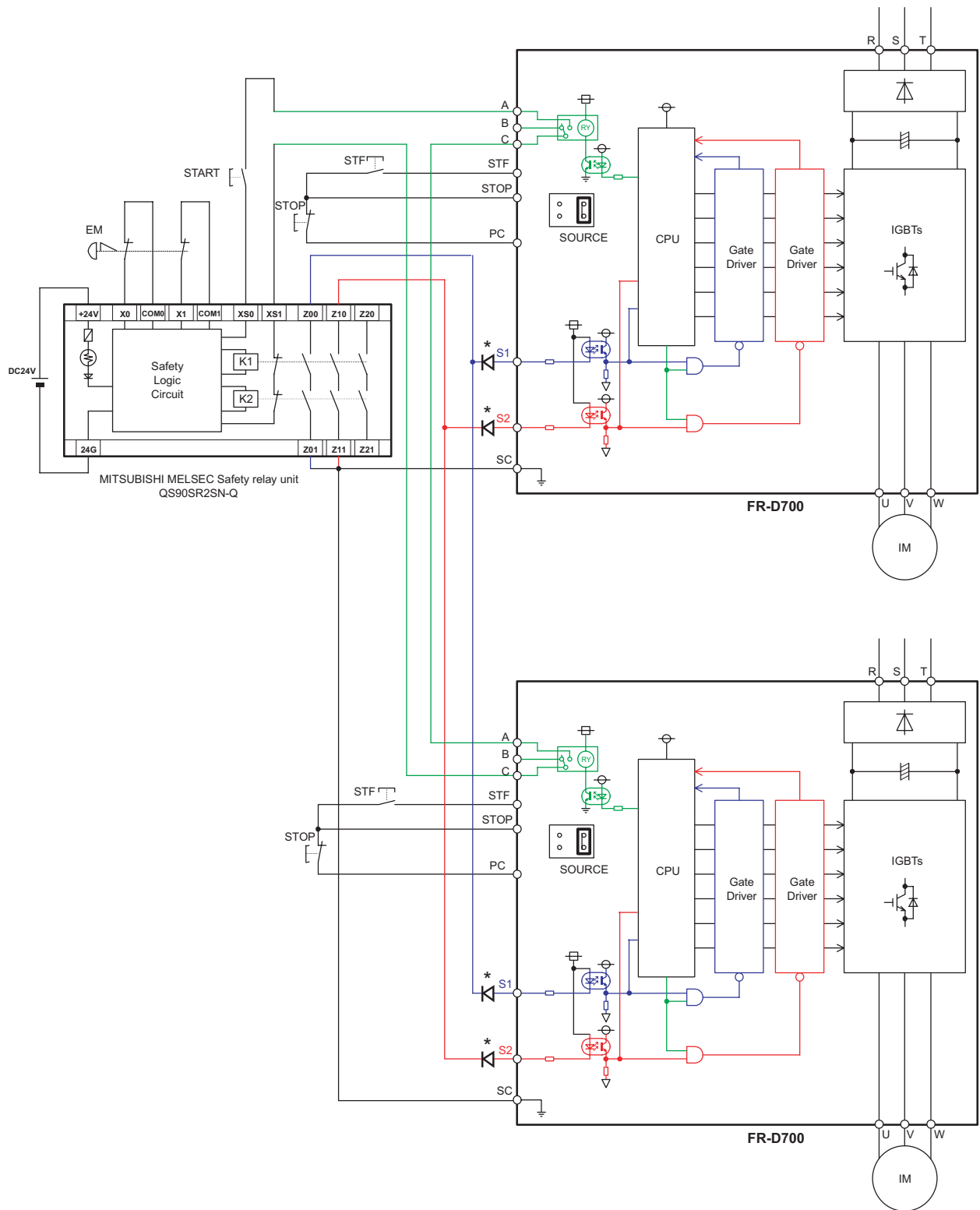

* When connecting multiple inverters, use a diode on the each safety input terminal to prevent a malfunction due to undesirable current.

Fig.4 Example of multiple inverters connected to a safety relay unit

The number of inverters connected to a safety relay unit should be decided under considerations of output terminal rating of a safety relay unit.

Example 2

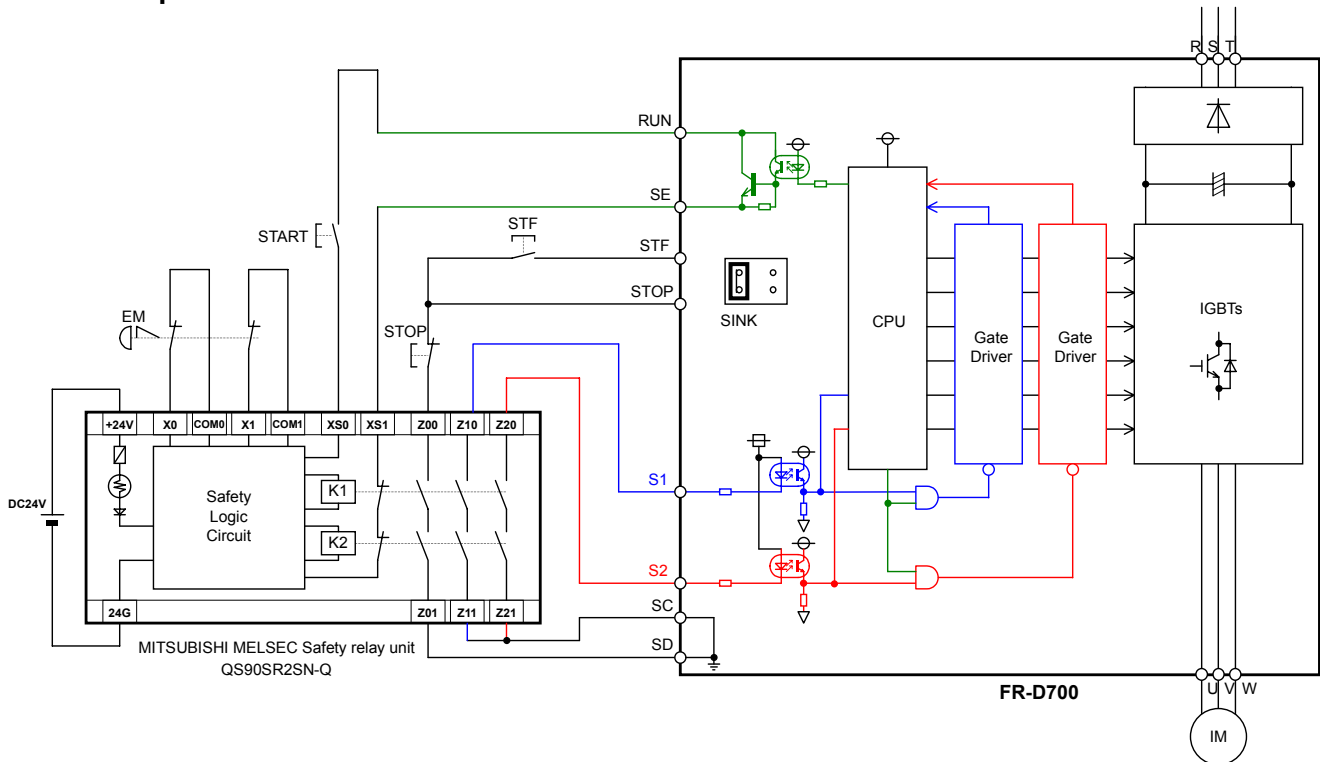

Fig.5 Safety system example 2 – STOP synchronous with EM and fault detection through RUN output.

For safety stop, configure the wiring as shown in Fig.4 above.

Note: the above wiring is configured to prevent restart in case of a fault.

XS0 should be connected to RUN terminal and XS1 should be connected to SE, because polarity of XS0 is positive, XS1 is negative.

The parameter No.190 must be set to '199'. This setting makes the RUN output to turn off in case of failure.

After the power-up, to reset the safety stop mode, press the START switch, and also press the STF switch, then start the motor rotation.

In the above Fig.4, wired example2, in the event of reset of 'safe-condition' the motor rotation will not occur until STF is pressed.

(for normal 'non-safety' STF/STOP function, please refer to your drive's *User Manual*)

ATTENTION

To prevent restart in case of recovering from input power loss of drive, 3-wired connection for STF/STOP control is recommended.

In case of 2-wire connection and using latching type switch to short between STF and SD/PC for starting, ensure the compliance with safety requirement for the restarting when the drive recover from input power loss.

4. Test and checking failure

ATTENTION

To avoid systematic faults, a test even for faulty demands of the safety function has to be performed in order to check the correct function of the monitor signal. This test shall be carried out at system installation, any software changes, parameterization changes, and/or at least once per year.

I/O status and failure

FR-D700 safety related I/O status obeys the following truth table.

Table.5 Truth table of Safety related signals

Input power	S1-SC	S2-SC	Failure	SO-SC	RUN-SE or A-C	Drive state
OFF	-	-	-	OFF(Open)	OFF(Open)	Drive shutoff (Safe state)
ON	Short	Short	No failure	OFF(Open)	ON(Close)	Drive enable
			Detected	OFF(Open)	OFF(Open)	Drive shutoff (Safe state)
	Open	Open	No failure	ON(Close)	ON(Close)	Drive shutoff (Safe state)
			Detected	OFF(Open)	OFF(Open)	Drive shutoff (Safe state)
	Short	Open	Detected	OFF(Open)	OFF(Open)	Drive shutoff (Safe state)
	Open	Short	Detected	OFF(Open)	OFF(Open)	Drive shutoff (Safe state)

In case of diagnostic or functionality test, check the I/O state whether it is same or not as Table.5.

Diagnostic

If the failure detected, FR-D700 output alarm signal and indicate 'E.SAF' at the display.

In case of FR-D700 output the alarm, please take following action.

- (1) Check the S1-SC and S2-SC input signal logic is the same. If these are different logic, collect the input signal and reset the FR-D700.
- (2) Disconnect the wire from S1, S2, SC terminal, then reset or power-off and on, If the 'SA' letter is flashed up at display, there is failure in system except FR-D700. But, still 'E.SAF' is displayed and alarm output, there is malfunction on FR-D700.

Self diagnostic test

FR-D700 does the self-diagnostic test on the power-ON.

If FR-D700 output alarm at power-ON, please take the action described in 'Diagnostic' at above.

Test procedure for functionality

As depicted 'ATTENTION' in above, the test for the functionality is important.

Please do the test following procedure.

- (1) Please make each state of S1-SC and S2-SC depicted at Table.5.
- (2) If there is any different state from Table.5, FR-D700 has some malfunction.
- (3) If there is no different state from Table.5, check the systematic performance, such as, press the Emergency switch, press the start/restart button at the failure detected (RUN-SE opened), and so on.
- (4) Finally clear the error record of the FR-D700 (see the user manual how to clear the error record).

REVISIONS

Print Date	Manual Number	Revision
Aug. 2009	BCN-A211508-000-C	First edition
Dec. 2009	BCN-A211508-000-D	<u>Change</u> Example of Safety stop connection

Ihr Partner für elektrische Antriebe / your partner for electrical drives



®

EP ANTRIEBSTECHNIK GmbH

Fliederstraße 8

Postfach 1333

63486 Bruchköbel

63480 Bruchköbel

Telefon +49 (0)6181 9704-0

Telefax +49 (0)6181 9704-99

e-mail: info@epa-antriebe.de

www.epa-antriebe.de

Änderungen und Irrtümer vorbehalten. / We reserve the right to changes without further notice.